



SIE-C843-9.2  
DESCRIPTIVE  
INFORMATION

**YASNAC<sup>®</sup> LX3/MX3**

# **ACGC 120**

## **CONNECTING MANUAL**

This manual describes the connection with the ACGC 120, which is an option of the YASNAC LX3/MX3 series, featuring the man-machine interface function with the high-performance 14-inch color CRT.

Operators should become thoroughly familiar with this manual before using the ACGC 120.

---

### TABLE OF CONTENTS

1. ACGC 120 OVERVIEW .....	2
1.1 OVERVIEW OF THE PRODUCT .....	2
1.2 OVERVIEW OF THE CONTROL MODULE .....	4
2. ENVIRONMENTAL CONDITIONS .....	5
3. STRUCTURAL DESIGN OF THE CABINET .....	5
4. THERMAL DESIGN OF THE CABINET .....	6
4.1 SELECTION OF THE HEAT EXCHANGER .....	6
4.2 TOTAL HEAT GENERATION OF EACH UNIT .....	7
5. CONNECTION DIAGRAM .....	8
6. SETTING THE MODULE SHORT-CIRCUIT PLUG SWITCHES .....	20
7. MEMORY SPACE .....	22
8. PRESHIPMENT SETTINGS .....	23
8.1 SYSTEM GENERATION (INITIAL SETTING) .....	23
8.2 SWITCHES .....	24
8.3 PARAMETERS .....	26
9. EXTERNAL DIMENSIONS.....	27
10. BATTERY MAINTENANCE.....	31

---

### SUPPLEMENT

In this manual, the terms "(printed circuit) board (card)" and "module" are used with the same meaning. The terms "portable" and "stand-alone" are also used with the same meaning.

# 1. ACGC-120 OVERVIEW

## 1.1 OVERVIEW OF THE PRODUCT

The product is classified into the following four types, from the hardware point of view.

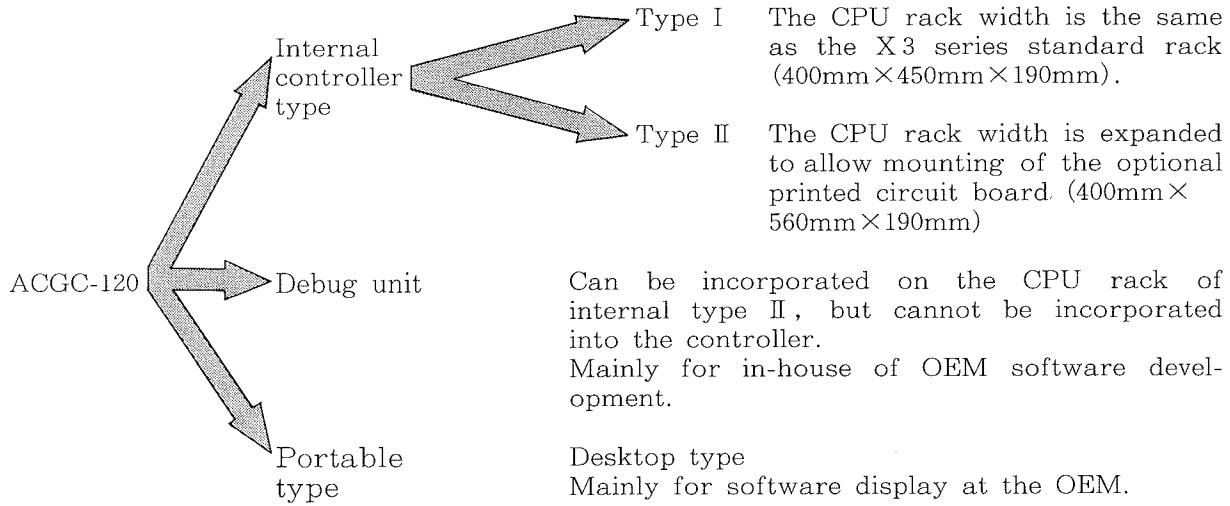

### (1) Internal type I

Type I is the basic type, where the NC is incorporated into the ACGC-120. The same CPU rack as the conventional X3 series is used, to incorporate the CPU into the NC. This eliminates the need to change the structure of the NC controller.

However, the size of the 14" color panel box is too small and some structural changes may be necessary.

The maximum capacity (option ROM 3 MB, RAM 1 MB) can be used for the application program created at the OEM.

### (2) Internal type II

Type II is the expanded type, where the ACGC-120 is incorporated into the NC.

The CPU rack width is somewhat larger than the conventional X3 series, and the structure of the NC controller may need changing.

Four more slots, as shown below, can be used to mount additional printed circuit boards. The structure is basically the same as type I except for this feature.

CNP connector ... Memory card for the OEM application software (option; ROM 3MB, RAM 1MB). The same memory card as that of type I is used.

CNS connector ... Two RS-232C ports, floppy disk drive interface card. The floppy disk drive is special to the debug unit, and cannot be mounted on the NC controller.

CNT connector ... }  
 CNU connector ... } Optional card for expanding functions (Spare)

### (3) Debug unit

Used when developing the application software at the OEM.

The open type unit is to be used in location having favorable environmental conditions.

The same CPU rack as that of internal type II is used, but the unit cannot be incorporated into the NC controller. As in type II, the cards that are mounted on the expanded 4 slots are as follows.

CNP connector ... Memory card for the OEM application software (option: ROM 3MB, RAM 1MB). The same memory card as that of type I is used.

However, special notice must be taken when setting the enable/disable status of the ROM on this card.

CNS connector ... Two RS-232C ports, floppy disk drive interface card. The 3.5-inch floppy disk drive can be used. This connector is used to upload/download the software created in the development environment of the NEC personal computer (PC-9800 series) with the debug unit.

The 3.5-inch floppy disk drive cannot be mounted on the NC controller.

CNT connector ... RAM memory card for development of the application software. Two-MB RAM is mounted on a single card, allowing address setting anywhere in the 1 to 16 MB memory space, in 1 MB unit. The address setting is simply done by the rotary switch on the card. This card is designed to change the ROM area on the memory card of the 1st slot into a RAM, and cannot be applied to the product.

CNU connector ... Same as the CNT connector

In addition to the above, the following optional peripheral tools are offered for debugging.

- Full keyboard
- 9" CRT panel
- I/O simulator

### (4) Portable type

The ACGC-120 control card alone is stored in a specialized box. The NC side does not function. This type is provided for displaying the system in the showroom at the OEM. The application software of the OEM alone can be debugged. It can also be expanded into an automatic program creation machine. The features are as follows.

- Two 3.5" floppy disk drives in the standard configuration
- Cabinet specialized for 15" color CRT (incorporating a TV tuner)

## 1.2 OVERVIEW OF THE CONTROL MODULE (\* : Optional modules)

Module Name	Function	Internal Type I	Internal Type I	Debug Unit	Portable Type	Remark
CG23	<ul style="list-style-type: none"> <li>• CPU module, mounting system PROM</li> <li>• One RS-232C channel</li> <li>• Full keyboard interface connector</li> <li>• Interface connector with SP23 module (Video signal, power ON/OFF signal, keyboard signal)</li> <li>• System number switch (rotary switch) is mounted</li> </ul>	○	○	○	○	
CG24	<ul style="list-style-type: none"> <li>• Graphic control module</li> </ul>	○	○	○	○	Mounted above the CG23 module
* CG25	<ul style="list-style-type: none"> <li>• Floppy disk drive interface (the debug unit alone supports the floppy disk drive)</li> <li>• Two RS232-C channels</li> </ul>		○	○	○	The floppy disk drive cannot be mounted on the internal type.
CG26	<ul style="list-style-type: none"> <li>• OEM application memory module P-ROM 1.25MB (max.) S-RAM 0.5MB (max.)</li> <li>• Battery unit is mounted as backup for the S-RAM</li> <li>• The mounted P-ROM can be set to be enabled or disabled.</li> </ul>	○	○	○	○	
* CG27	<ul style="list-style-type: none"> <li>• OEM application optional memory module P-ROM 1.75MB (max.) S-RAM 0.5MB (max.)</li> <li>• The S-RAM is backed up by the battery unit of the super C and the CG26 module.</li> <li>• The mounted P-ROM can be set to be enabled or disabled.</li> </ul>	○	○	○	○	Mounted above the CG26 module
* CG28	<ul style="list-style-type: none"> <li>• CPU bus expansion module</li> <li>• External power supply interface connector is mounted for enforcement</li> </ul>		○	○		
* CG29	<ul style="list-style-type: none"> <li>• S-RAM module for development of application software at the OEM</li> <li>• The memory capacity is 2 MB, and the memory address is set using the rotary switch in 1 MB unit.</li> <li>• The SRM is backed up by the battery unit of the super C and the CG26 module.</li> </ul>			○ Two module possible	○ Two module possible	Used to replace the memory space of the P-ROM mounted on the CG26/CG27 module by the S-RAM, when developing the application software.
SP23-1	<ul style="list-style-type: none"> <li>• Interfaces the following signals with the CG23 module. Video signal, Power ON/OFF signal, Keyboard signal</li> <li>• Power ON, OFF switch interface connector</li> <li>• Video signal interface connector for 14" color CRT</li> <li>• Mounted with keyboard interface connector and keyboard selection switch</li> <li>• Detach keyboard interface connector</li> </ul>	○	○			
* SP23-2	<ul style="list-style-type: none"> <li>• SP23-1 module functions plus the video printer interface are mounted.</li> </ul>			○	○	
* CG30	<ul style="list-style-type: none"> <li>• Same as the CG28 functions, but the mountable modules have been increased.</li> </ul>				○	

## 2. ENVIRONMENTAL CONDITIONS

- (1) Ambient temperature    During operation 0°C to 45°C  
                                 During storage -20°C to +60°C
- (2) Humidity                    10 to 90 % RH (relative)  
                                 (Non condensing)
- (3) Vibration                    0.5 G or less

## 3. STRUCTURAL DESIGN OF THE CABINET

Consider the following when designing the cabinet to accommodate the CPU rack and other units.

- (1) The cabinet must always be of closed structure.

However, the cabinets of feed servo units and spindle drive units may be of ventilated type, when the following conditions are satisfied.

- (a) Set an air filter at the outside air inlet.
- (b) Do not let the airflow of the internal fan blow directly on the unit, or oil mist and dust may adhere to the unit and cause failure.
- (c) Decide the air outlet position where dust and oil mist do not enter the cabinet.

The radiation fin of the feed servo unit and spindle drive unit extends out of the structure. Placing the radiation fin outside the cabinet, decreases the internal thermal loss, thus improving the reliability. The closed structure is recommended for this reason.

- (2) Design the cabinet so that the difference between the internal temperature rise and the outside air is 10°C or less. See section 5 for the thermal designing of the cabinet.
- (3) Use a fan to circulate the air within the closed cabinet so as to improve the cooling efficiency and to prevent local temperature rise. Take necessary measurements so that an airflow of 2 m/s or more flows above the surface of the printed circuit board. Be careful not to let the airflow of the fan blow directly on the printed circuit board.
- (4) Locate the parts considering the flow of the air. Secure about 100 mm clearance from the cabinet wall so as not to obstruct the air flow.
- (5) Seal the cable inlet and door firmly.

The high-voltage CRT needs special consideration, as it collects the dust in the air.

The following must be observed, on the CRT mounting cabinet.

- (a) Seal the mounting surface with packing, and make sure that there is no space.
  - (b) Seal the cable inlets and doors with packing.
- (6) Distortion of the CRT display caused by magnetism:

The CRT display may be distorted by the surrounding magnetism. Keep any magnetic source (e.g. transformer, reactor, fan, magnetic relay, solenoid relay, AC power supply cable, etc.) about 300 mm away from the CRT unit.

## 4. THERMAL DESIGN OF THE CABINET

### 4.1 SELECTION OF THE HEAT EXCHANGER

The cabinets that accommodate the CPU module and other units are to be of closed structure, and the internal temperature rise kept within 10°C of the ambient air temperature.

To satisfy the above conditions, a thermal heat exchanger may be required inside the cabinet, according to the installed electrical parts.

Determine the capacity of the heat exchanger as follows.

- $\Delta T$  : Temperature rise within the cabinet (degrees C)
- $P_v$  : Total heating value (W)
- $k$  : Heat transmittance [ $W (m^2 \cdot ^\circ C)$ ]  
Calculate with  $6 W(m^2 \cdot ^\circ C)$  when circulating fan is provided.
- $A$  : Effective radiation area of cabinet ( $m^2$ )
- $q_h$  : Required heat exchanger effectiveness

- (1) Calculate the total heating value  $P_v$  of the electric parts.

$$P_v = \Sigma (\text{Heating value of each unit})$$

- (2) Calculate the effective radiation area  $A$ .

$$A = 2 \times \{W (\text{width}) \times H (\text{height})\} + s \{W (\text{width}) \times D (\text{depth})\} + 2 \{D (\text{depth}) \times H (\text{height})\}$$

Surfaces that do not contact the outside air are considered non-effective surfaces.

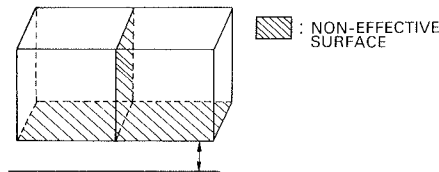

When a bottom is 50mm or less above the floor surface, this bottom surface is considered a non-effective surface.

- (3) Calculate the allowable heating amount  $P_v'$ , as the internal temperature rise is  $\Delta T$  or less than 10°C.

$$P_v' = k \cdot A \cdot \Delta T \quad (W)$$

$\Delta T$  → 10°C  
 $k$  → 6 W/(m<sup>2</sup>·°C)

- (4) No heat exchanger is necessary if it is:

$$(\text{Total heating value}) \leq (\text{Allowable heating value } P_v')$$

- (5) Heat exchanger with the following effectiveness  $q_h$  is required if it is:

$$(\text{Total heating value}) > (\text{Allowable heating value } P_v')$$

$$q_h = (P_v - P_v') / \Delta T \quad (W / ^\circ C)$$

$\Delta T$  → 10°C

## 4.2 TOTAL HEAT GENERATION OF EACH UNIT

### (1) NC unit

Unit	Heating Value (W)
CPU module	70
NC control panel	20
Tape reader	25
I/O module	5

### (2) ACGC-120 unit

Control Module/Unit	Heating Amount (W)	Remark
JANCD-CG23	5	
JANCD-CG24	6	
JANCD-CG25	2.5	Optional module
JANCD-CG26	5	
JANCD-CG27	1.5	Optional module
JANCD-CD28	0.1	Optional module
JANCD-CG29	0.5	Module for debug unit
JANCD-SP23	2.5	
JANCD-CG30	0.1	Module for portable type
14" color CRT	MAX.100 TYP.70	

# 5. CONNECTION DIAGRAM

## 5.1 YASNAC LX3 (ACGC 120) GENERAL INTERCONNECTION DIAGRAM (Internal type I)

\* : Optional module

ACGC 120 control unit

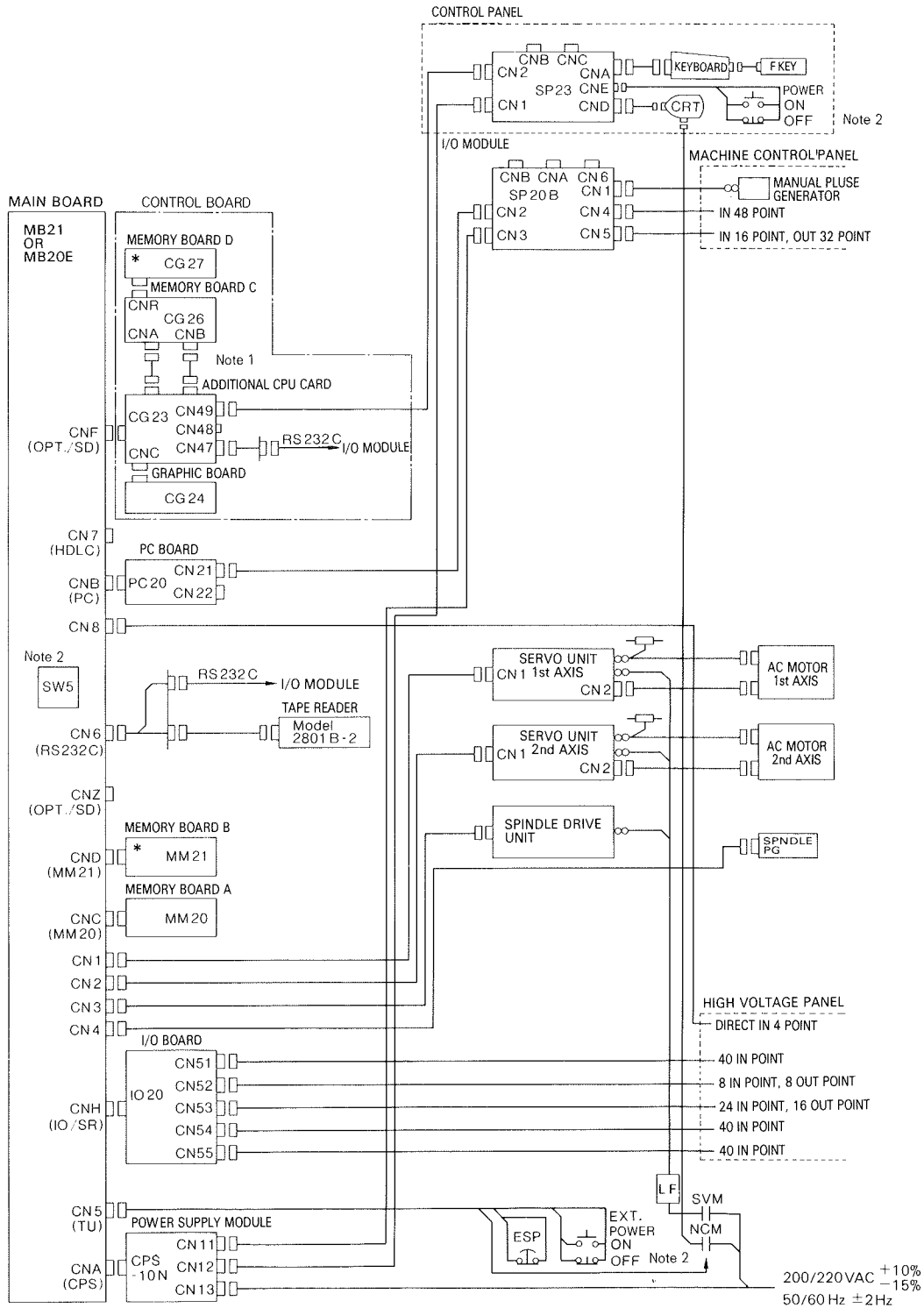



# 5.2 YASNAC LX3 (ACGC 120) GENERAL INTERCONNECTION DIAGRAM (Internal type II)

\* : Optional module

ACGC 120 control unit

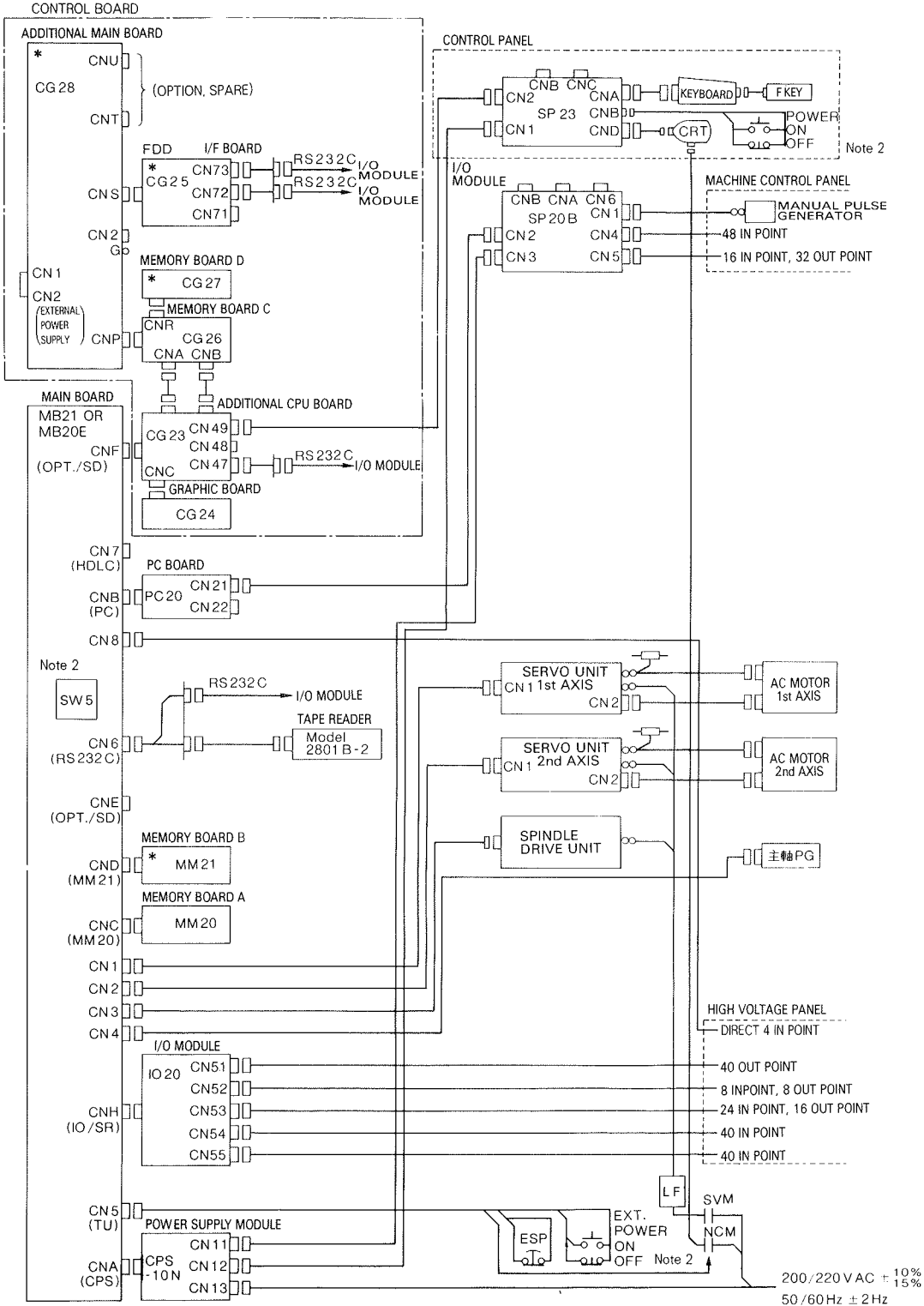

# 5.3 YASNAC MX3 (ACGC 120) GENERAL INTERCONNECTION DIAGRAM (Internal type I)

\* : Optional module

ACGC 120 control unit

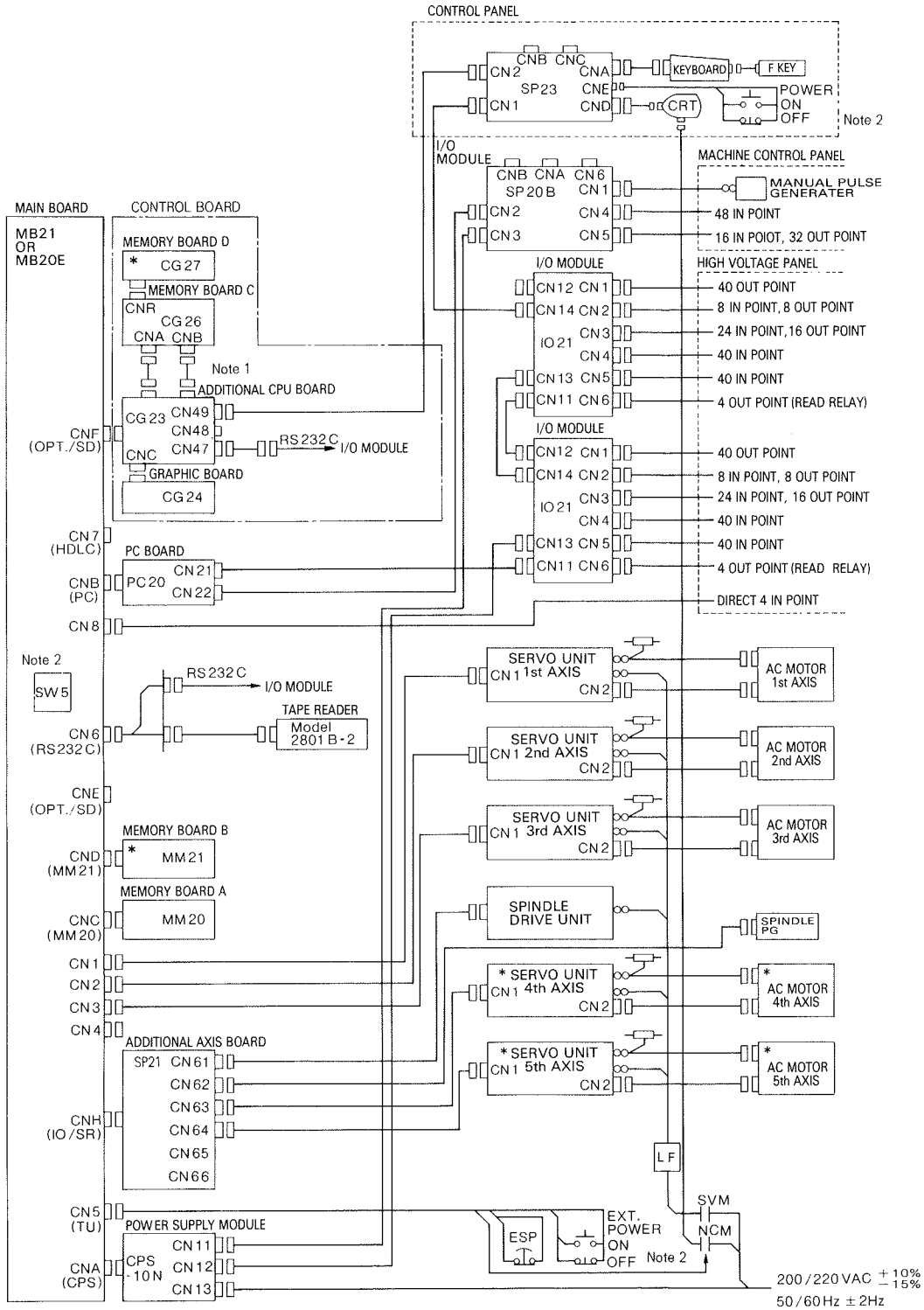

# 5.4 YASNAC MX3 (ACGC 120) GENERAL INTERCONNECTION DIAGRAM (Internal type II)

\* : Optional module

ACGC 120 control unit

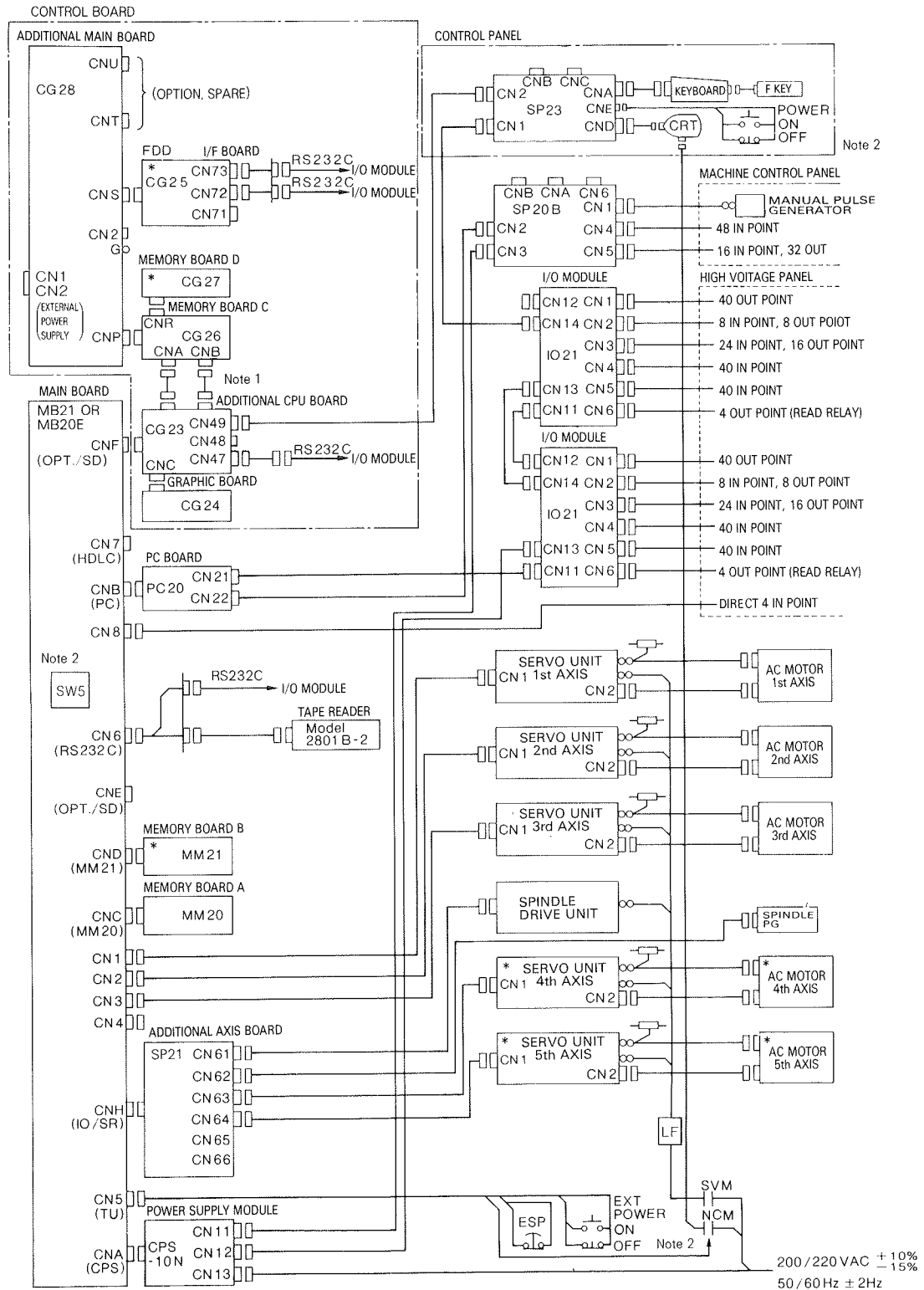

# 5.5 ACGC 120 CABLE CONNECTION DIAGRAM (1/2)

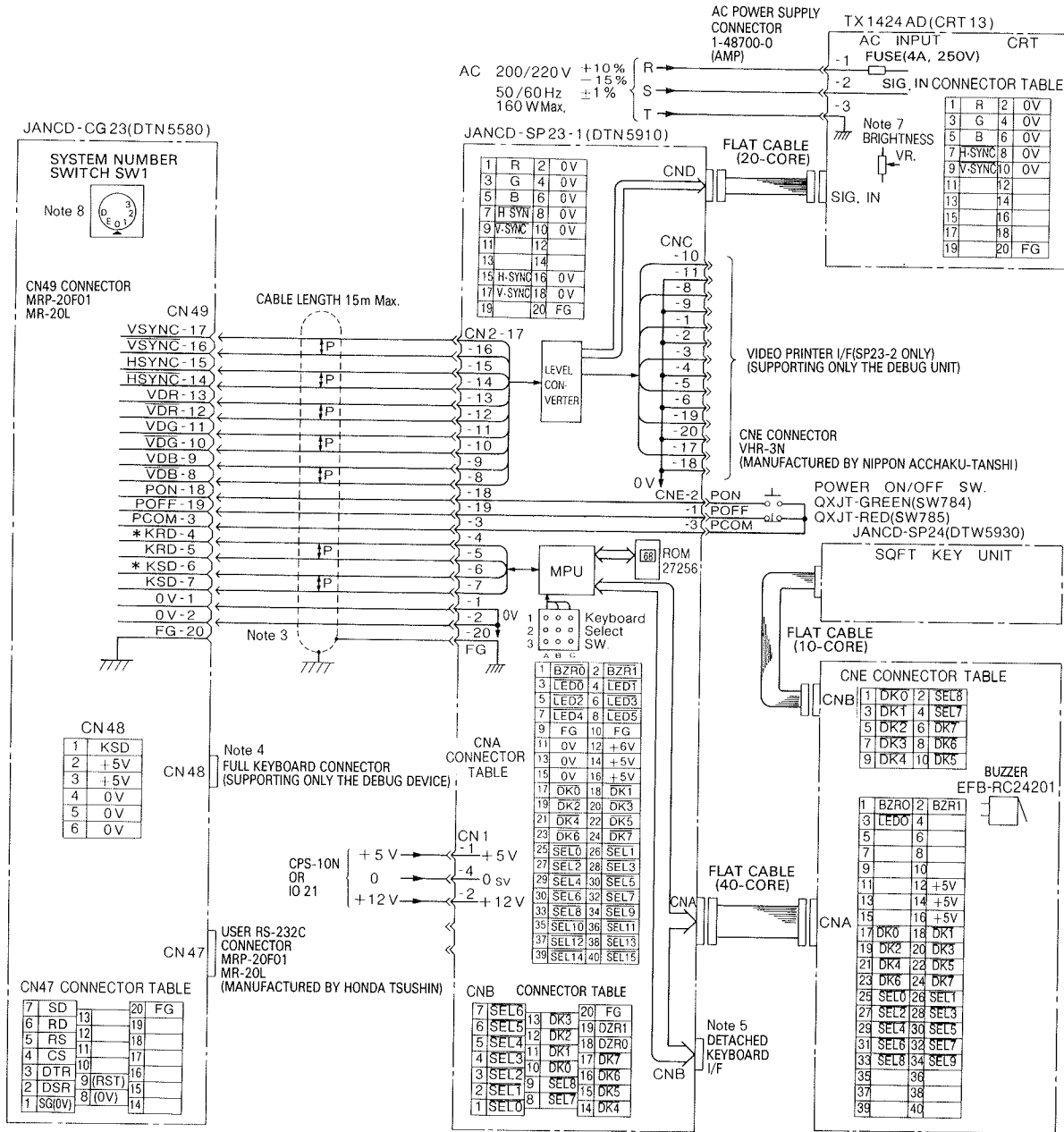

## 5.5 ACGC 120 CABLE CONNECTION DIAGRAM (2/2)

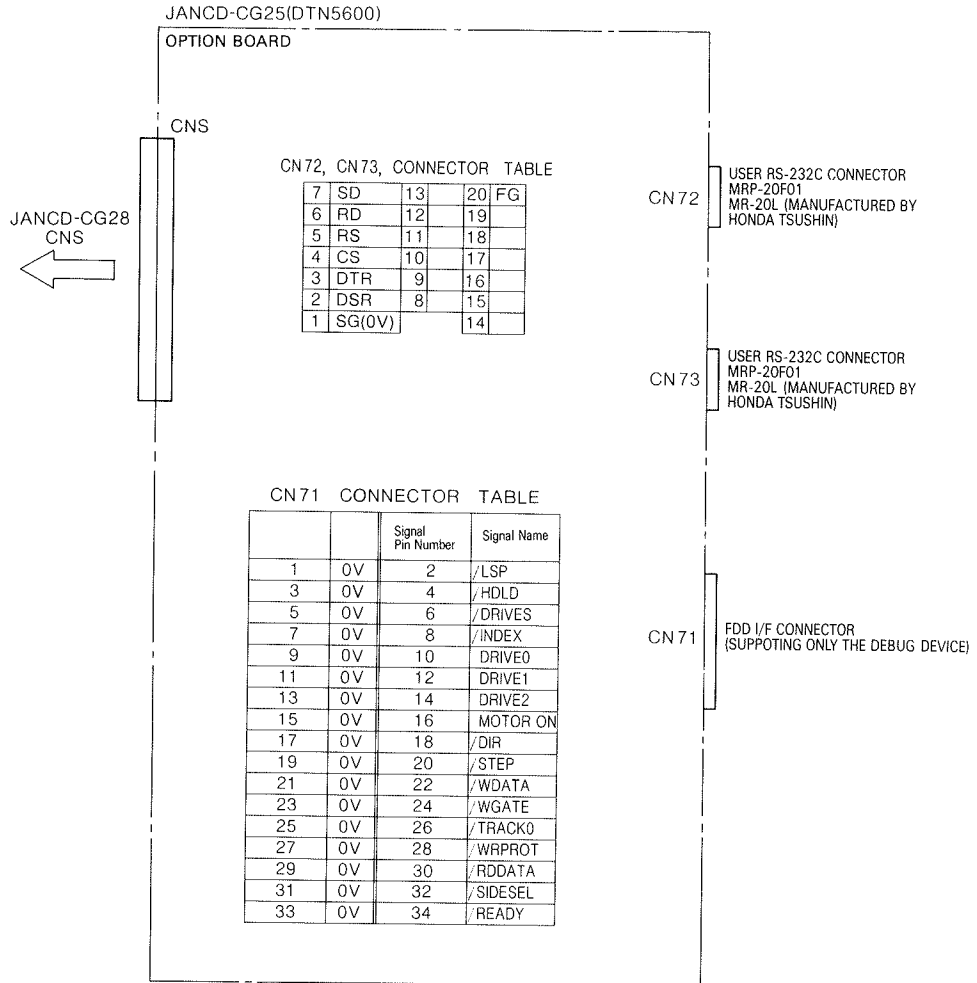

[CONNECTORS]

• List of CPU Module Connectors

CPU Module Name	Connector No.	Board Side Connector Name	Cable Side Connector Name
JANCD-CG23	CNA	FRC2-C50L12-OL	Connected
	CNB	FRC2-C50L12-OL	Connected
	CN47	MR-20RMA	MRP-20F01
	CN48	TM5RA-66	Free
	CN49	MR-20RMA	MRP-20F01

• List of Panel Connectors

CRT Panel Name	Connector No.	Board Side Connector Name	Cable Side Connector Name
JANCD-SP23	CNA	FRC2-C40L12-OL	Connected
	CNB	MR-20RFA	Free
	CNC	MR-20RFA	Free
	CND	FRC2-C20L12-OL	Connected
	CNE	B3PS-VH	Connected
	CN1	172040-1	172026-1
	CN2	MR-20RMA	MRP-20F01
CRT unit	Power supply	1-480701-0	1-480700-0
	Signal	FRC2-C20L12-OL	Connected

[RS-232C Interface]

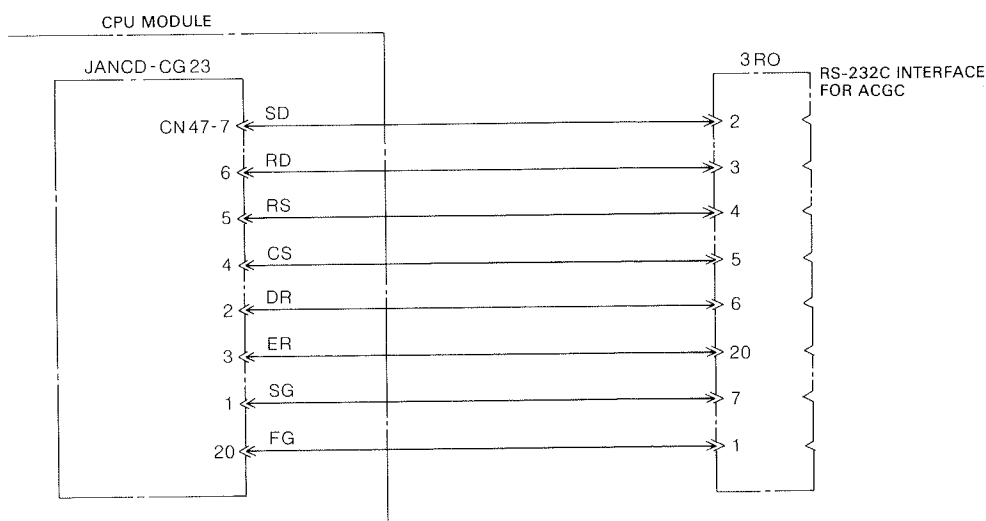

## 5.6 NOTES ON THE CONNECTION DIAGRAMS

Note 1 Connect between CG23 and CG26 modules with two 50-core flat cables, as follows.

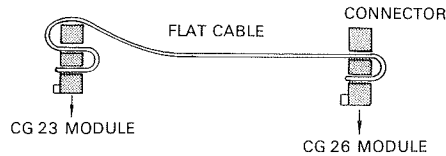

Note 2 The power can be supplied or disconnected by the panel power ON/OFF (POF) or the external power ON/OFF (EOF). The following selection can be done on the main card (MB21 or MB20E) short circuit plug SW5. The SW5 also allows selection of the 9" CRT (basic) or 14" CRT (optional).

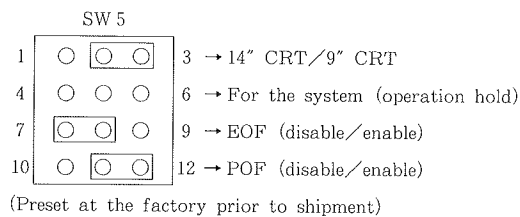

Setting of SW5

	To Use Only Panel (POF)	To Use Only External (EOF)	To Use Both
SW 5	1 <input type="radio"/> <input type="radio"/> <input type="radio"/>	3 <input type="radio"/> <input type="radio"/> <input type="radio"/>	1 <input type="radio"/> <input type="radio"/> <input type="radio"/>
	4 <input type="radio"/> <input type="radio"/> <input type="radio"/>	6 <input type="radio"/> <input type="radio"/> <input type="radio"/>	4 <input type="radio"/> <input type="radio"/> <input type="radio"/>
	7 <input type="radio"/> <input type="radio"/> <input type="radio"/>	9 <input type="radio"/> <input type="radio"/> <input type="radio"/>	7 <input type="radio"/> <input type="radio"/> <input type="radio"/>
	10 <input type="radio"/> <input type="radio"/> <input type="radio"/>	12 <input type="radio"/> <input type="radio"/> <input type="radio"/>	10 <input type="radio"/> <input type="radio"/> <input type="radio"/>

Always set Nos. 4 and 6 of SW5 open.

Note 3 Make sure that the shield line of the signal cable is treated as follows.

- (1) When the control panel and the NC control unit are separated (the cable connection diagram shows this separated case)

In this case, always use the shielded cable. Strip the outer cover of the cable and clamp the cable so that the shielding cover is grounded to the grounding plate.

This prevents external noise from flowing into the control unit. Also connect the outer shielding cover to the CN2-20 pin of the SP23 module.

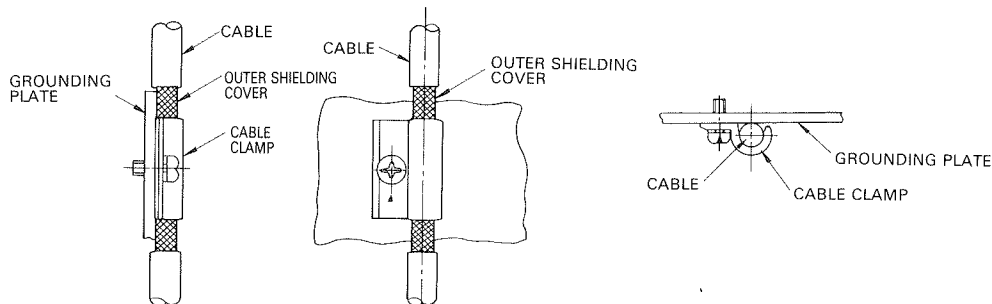

## 5.6 NOTES ON THE CONNECTION DIAGRAMS (Cont'd)

(2) When the control panel and the NC control unit are of integrated structure

(a) When using the cable

Generally, follow method (1). The following simple way can also be used, but in this case, always perform a noise test.

Also, use shielded cable wherever possible. But there is no need to use the cable clamp as in (1). Connect one end of the outer shielding cover (the end at the CPU module side) with the FG pin on the connector.

Though the above single-end connection is to be basically applied, the wiring path or the configuration of the control unit may require a two-end connection to improve the noise resistance. Evaluate the connection with a noise test.

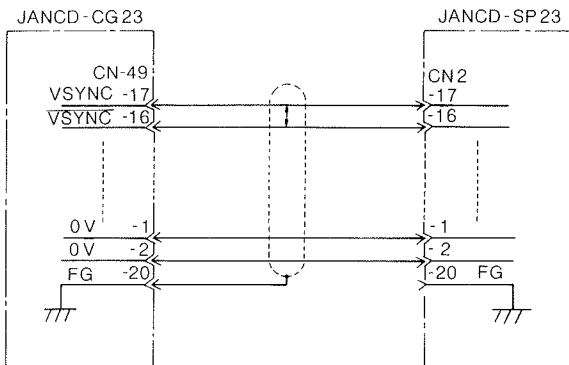

### Simple method

In an integrated structure, the cabinet acts as a shield against external noise. The noise sources that affect the signal cable are the feed servo drive unit, spindle drive unit, magnetic relay unit within the NC unit, and the I/O cable, servo/spindle PG cable, and AC power supply cable that are connected outside the NC unit.

The wiring path, line binding method, etc. can be arranged to prevent this noise interference.

When using cables without shielding, no special connection is required, but be careful of the binding. Keep the I/O cable, PG cable of the servo, AC power cable that can become the source of noise separated from each other. Also, always perform evaluation with a noise test.

(b) When using single lines

Connection with single lines is generally not allowed. However, only when the distance between the CG23 and SP23 modules is short and a shielded cable cannot be used, use a single line, taking care of the following.

- Use single lines of 0.3mm<sup>2</sup> or above.
- Keep the I/O cable, PG cable of the servo, AC power cable that can become the source of noise separated from each other. Always evaluate the noise by performing noise test.
- Treat the twisted pair lines with care.
- Always perform noise test to evaluate the noise.



Note 4 The full keyboard is provided only for the debug unit.  
Do not use full keyboards other than specified by YASKAWA.

Full keyboard model B5GS-C098-406 (manufactured by OMRON)

Note 5 The detached keyboard function allows the keyboard to be attached and detached to from the control panel. This function is used when operating the keyboard for some time, to establish a detached keyboard box, to permit key operation while sitting.

The function is used as follows. The cable length is to be within 3 m from the SP23 module. The detached keyboard box, using the standard vertical keyboard, is offered as an option.

Example 1

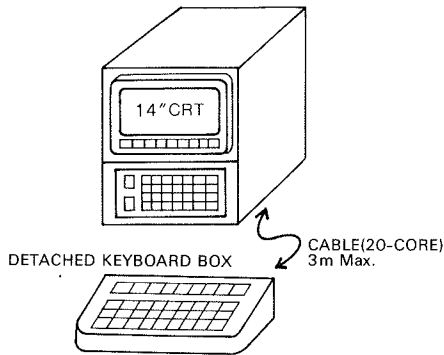

Example 2

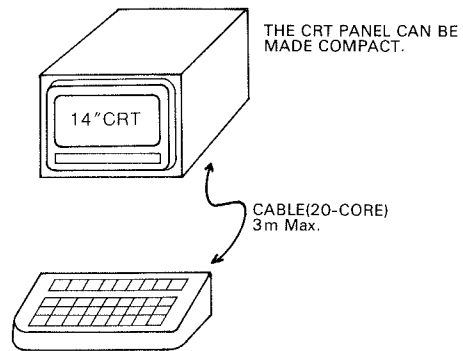

Note 6 Select the keyboard select switch SW1 short-circuit plug, according to the corresponding keyboard. The following is the method for setting the standard vertical and horizontal keyboards. Contact your Yaskawa representative when a specialized keyboard is produced by the OEM. In this case, our system software development will be required. Also refer to Par. 9.2 for details on the OEMs.

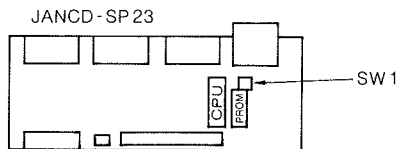

SW1 (Four A, B, and Cs are not used)

1	<input type="checkbox"/> <input type="checkbox"/> <input type="checkbox"/>	Set the keyboard of the standard vertical CRT unit. (The keyboard is at the lower side of the CRT)
2	<input type="checkbox"/> <input type="checkbox"/> <input type="checkbox"/>	
3	<input type="checkbox"/> <input type="checkbox"/> <input type="checkbox"/>	
4	<input type="checkbox"/> <input type="checkbox"/> <input type="checkbox"/> A B C	
1	<input type="checkbox"/> <input type="checkbox"/> <input type="checkbox"/>	Set the keyboard of the standard horizontal CRT unit. (The keyboard is at the right side of the CRT)
2	<input type="checkbox"/> <input type="checkbox"/> <input type="checkbox"/>	
3	<input type="checkbox"/> <input type="checkbox"/> <input type="checkbox"/>	
4	<input type="checkbox"/> <input type="checkbox"/> <input type="checkbox"/> A B C	

## 5.6 NOTES ON THE CONNECTION DIAGRAMS (Cont'd)

Note 7 The left rear side of the 14" color CRT. Sections A to D are as follows.

- A ..... AC power 100V/220V selection switch for the 14" color CRT. When setting up, always check that the switch is set at the 220V side before supplying the power. If 200 VAC or higher is connected with the switch set at the 100V side, the CRT will fail. The upper and lower set screws can be loosened to change the setting. The 100V side is normally not used.
- B ..... Connector where the SP23 module CND connector and flat cable (20-core) are connected. Video signal input connector.
- C ..... CRT brightness adjustment variable resistor. The resistor is adjusted at the standard value at the factory before delivery and needs no further adjustment under normal circumstances. Setting the CRT brightness at unnecessarily high value will shorten the life of the CRT. When not viewing the CRT while the power is supplied, depress the 

CRT OFF
------------

 key on the keyboard (standard keyboard) to set the CRT in stand-by mode (the CRT turns black) which can prolong the life of the CRT. Press the key once more to activate the CRT.
- D ..... The AC power input connector for the 14" color CRT. See A above for the method to select 100V or 220V AC power.

AC power specifications 200/220V +10% -15%, 50/60Hz  $\pm$ 1%, 100W max. (typ. 70W)

AC power input connector type 1-480700-0 (AMP Co.) 3-pin lock connector.

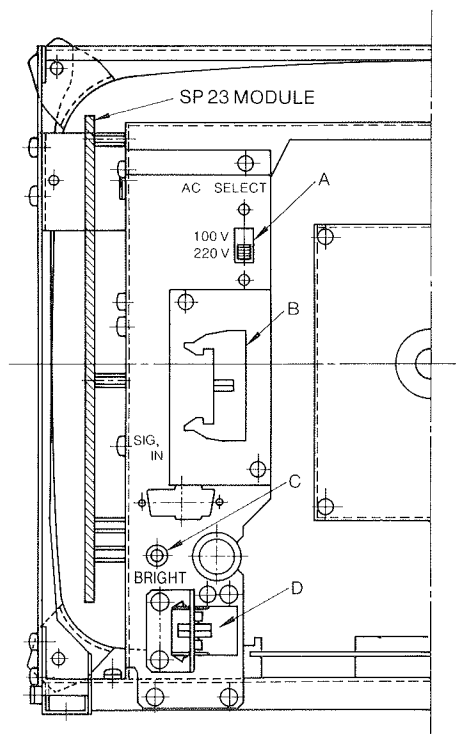

Note 8 0 to E can be set with the rotary switch SW1 (hereafter called system number switch) at the upper right corner or the CG23 module. Note the following when setting.

(1) The end user

Keep the system number switch fixed at 0. The switch will be delivered from the machine tool manufacturer with the system number switch set at 0, so no setting is necessary by the user. Starting the machine with the setting at other than 0 may cause the system to fail. Also note that the self diagnosis function does not work during operation.

(2) The machine tool manufacturer

Keep the system number switch fixed at 0, as with the end users, if not developing the application software. However, parameter setting and alteration must be made with the system number switch set at 1. Always return the system number switch to 0 after setting and changing the parameters. Also check that the system number switch is set at 0 before shipping the system to the end users.

(3) System number switch settings 5 to E are for Yaskawa's system diagnosis mode.

The end user or machine tool manufacturer should never use these settings or the system will fail.

The operation modes for the setting on the ACGC 120 system number switch are as follows.

Setting, on the System Number Switch

System Number	0	1	2	3	4	5 - E
Specifications	Internal type	Debug unit	Portable type			Do not touch
Application	All commands and GMISC can be used.		Commands NCREQ, FREQ and the GMISC related to the NC cannot be used.			Program and data created by the conversational program will be destroyed.
Mode	Execution	Development	Execution	Execution	Development	Yaskawa's system diagnosis

① When the system number switch is set at 0

The system starts up, synchronizing with the NC, as power is supplied, to immediately execute the application program (index "1").

② When the system number switch is set at 1

The system starts up, synchronizing with the NC, as power is supplied, to display the application program development mode screen. The development mode screen is equivalent to the existing screen.

③ When the system number switch is set at 2

The system starts up in ACGC unit, as power is supplied, to immediately execute the application program (index "1").

④ When the system number switch is set at 3

This mode is basically equivalent to the system number switch 2 mode, but index "1" is not immediately executed as power is supplied, and the application program can be replaced by the floppy disk drive. The following are the specifications.

It is not necessary to input the alphabet key on the screen of application program replacement under these specifications.

Note that the file name created when merging is executed by the EXE.MRG utility and dividing the file, cannot be changed.

Multiple files cannot exist on a single diskette.

## 6. SETTING THE MODULE SHORT-CIRCUIT PLUG SWITCHES

The OEM should refer to Par. 9.2.

### (1) JANCD-CG26/CG27 module

Enable: EN  
Disable: DIS

Switch Name	Descriptions
SW2	Enables/disables the ROM mounted on the CG26/CG27 modules. Used to replace the ROM memory space to RAM on the CG29 module, when application software is developed using the debug unit or the stand-alone type at the OEM. Set the SW2 short-circuit plug at the DIS side, to disable the ROM on the module (ROM PROHIBIT status). The setting on delivery is at the EN side. No change is normally necessary by the machine tool manufacturer or end user.
(Also see Section 8.)	
SW1	Sets the CG26/CG27 modules at online mode or offline mode. Always set this switch at the NORMAL side (offline mode) 1 to 4. The VPP side (5 to 8) is used for factory maintenance (offline mode). If power is supplied with the setting at the VPP side, the ROM mounted on the module will be destroyed. The factory setting on delivery is at the NORMAL side. No change is normally necessary by the machine tool manufacturer or end user.

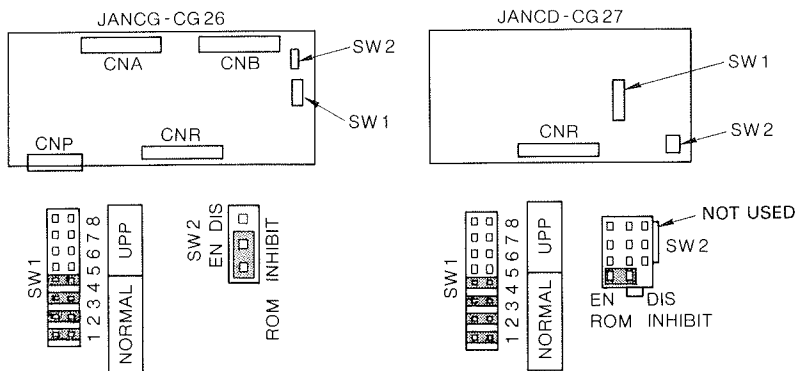

The SW2s in the above figures are both set at the EN (enable) side.

(2) JANCD-CG29 module

Switch Name	Description
SW2, 3 (Rotary switch)  (Also see Section 8.)	2 MB S-RAM is mounted on the CG29 module. The memory address can be set in 1 MB unit in this S-RAM, and SW2 and 3 are used to set the address. This module is used at the OEM to replace the ROM memory space of the CG26 and CG27 modules to RAM, when developing the application software using the debug unit or the portable type. SW2 and 3 can select 0 to F, but setting must be done according to the instructions in Par. 9.2.

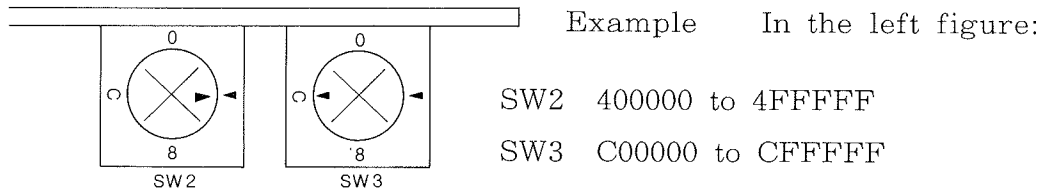

(3) JANCD-SP23 module

A short-circuit plug switch with "KEYBOARD" printed on it is mounted on the DC power connector CN1 side of this module. See Par. 6.6, Note 6 and Par. 9.2 for details.

"DOTCLK" is printed on the CNC connector side of the SP23-02. Set the pin between 1 and A, B as shown below. (The pin will be set at 1 - A, B at the factory before delivery.)

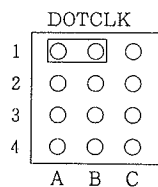

(4) JANCD-MB21 or MB20E module

Short-circuit plug switches with "SW5" printed on them are mounted on the CN4 connector side of both modules. See Par. 6.6, and Note 2 for details.

## 7. MEMORY SPACE

Module	Description	Capacity	Address	Application
JANCD-CG23	CPU Module	System RAM 352K	000000—057FFF	YASKAWA'S system
		System ROM 512K	080000—0FFFFFFF	YASKAWA'S system
JANCD-CG24	Graphic module Y-E character ROM	128k 64k	—	CRT Application
JANCD-CG26	Application ROM	1.25M	100000—23FFFF	Application
	Application RAM	512k	800000—87FFFFFF	Application
JANCD-CG27	Application ROM	1.75M	240000—3FFFFFFF	Application
	Application RAM	512k	880000—8FFFFFFF	Application
JANCD-CG29	Debug RAM	2M/1 disk	100000—7FFFFFFF 900000—FFFFFFF	Debug of the application

Can be specified within this range

The application RAM and debug RAM are backed up by the battery and the super capacitor. The super capacitors on cards other than CG26 are discharged, and then after a short period, the battery also starts to discharge. If the power off period is a single day, the super capacitor alone is enough for the backup, and the battery is not run down. The data on the cards are stored by the super capacitor even when the cards are removed. Note that the data on the CG26 are stored by the battery.

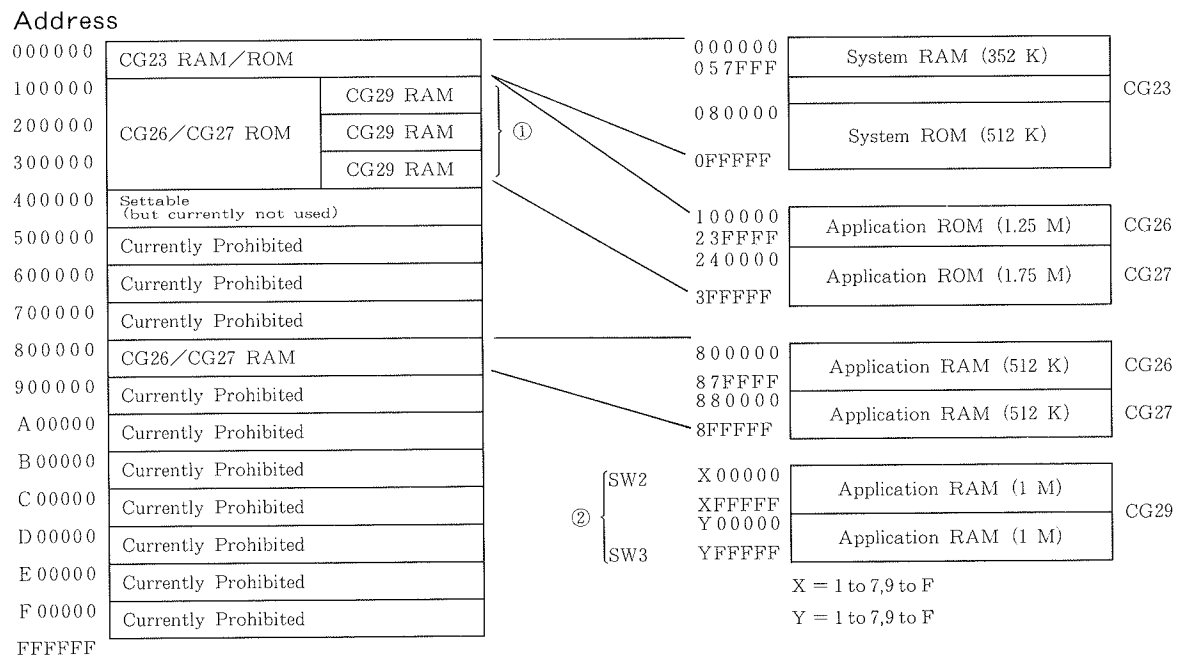

①The range of 100000 to 3FFFFFFF is normally the ROM of CG26 and CG27, but the RAM of CG29 can be assigned by setting the SW2 of CG26, CG27 at ROM INHIBIT. Also see Section 7 (1) and Par. 9.2.

②The physical address X, Y can be specified optionally by selecting SW2 and 3 of CG29. Also see Section 7 (2) and Par. 9.2.

## 8. PRESHIPMENT SETTINGS

### 8.1 SYSTEM GENERATION (INITIAL SETTING)

When the application software ROM (mounted on the CG26/CG27 module) is replaced at the machine tool manufacturer, perform system generation, NC connection check and after care as shown below.

Table. 9.1

Item	Operation	Remarks
Switch Setting	Set the switches on each module according to the setting method of each OEM. (See Table 9.2.)	If the switches are temporarily changed by the machine tool manufacturer, always return the setting to the original setting.
Generation under Development Mode	Preparation Set the CG23 system number switch at "4". (Stand-alone development mode)	Also see Par 6.6, and Note 8.
	Setting the Calendar 1) Turn on the power. 2) Depress <F6> to set the timer. 3) Depress DATE (F1). 4) Set the date Example May 26, 1988 → 880526 <WR> 5) Depress TIME (F2). 6) Set the time. Example 2:24:00 p.m. → 142400 <WR> 7) Depress EXIT (F9) (to return to the menu screen).	
	Setting the Parameter 1) Depress <F5> to set the parameter. 2) Depress GEN (F1). 3) Depress Y [or YES (F2)]. 4) Set the parameter according to the setting value of each OEM. (See Table 9.3.) 5) Depress <F9> to write the information. 6) Turn off the power.	
	Initializing the File 1) Turn on the power. 2) Depress <F3> for file operation. 3) Depress <F2> for generation. 4) Depress <F3> for all files. 5) Depress Y [or YES <F1>]. 6) Turn off the power	The CMOS file of the ACGC is cleared by this operation. If files that are to be kept are stored, save these files before the initialization.
	Preparation Set CG23 system number switch at "1" (development mode).	This step is not required in the portable type. Also see Par 6.6, and Note 8.
Connection with the NC Check	1) Turn on power. 2) Depress <F4> to display the NC screen.  The check is OK if the NC screen is updated by depressing the page key or cursor key.	This step is not required in the stand-alone type.
After Care Returning the System Number Switch	1) Turn off power. 2) Return the CG23 system number switch to "0". The above completes the system generation.	

## 8.2 SWITCHES

See Section 7 for details on the functions.

The setting may change because of changes made in the system, or by additional optional modules. Update Table 8.2, according to Yaskawa's instructions for revision.

Table 8.2 Setting of Each Module (1/2)

(As of April 1, 1988)

Module	CG 26		CG 27		CG 29			SP 23	
	SW 1	SW 2	SW 1	SW 2	SW 2	SW 3	SW 2	SW 3	SW 1
OEM A									
OEM B									
OEM C									
OEM D									



Table 8.2 Setting of Each Module (2/2)

(As of April 1, 1988)

Module	CG 26		CG 27		CG 29				SP 23				
Switch	SW 1	SW 2	SW 1	SW 2	SW 2	SW 3	SW 2	SW 3	SW 1				
OEM E													
Portable Type													 Refer to par. 5.6 Note 6.
Debug Type													 Refer to par. 5.6 Note 6.

### 8.3 PARAMETERS

See Par 9.1 for details on how to set the parameters.

The contents of the parameters are displayed on the parameter setting screen. The setting value of the parameters may change because of changes made in the system, or by additional optional modules. Update Table 8.3, according to Yaskawa's instructions for revision. Set the debug unit according to the specifications of the OEM.

Table 8.3 Setting of the ACGC parameters (As of April 1, 1988)

	Parameter	Setting Value		Parameter	Setting Value
OEM A	# 000	000	OEM B	# 000	000
	# 001	003		# 001	003
	# 002	001		# 002	001
	# 003	000		# 003	000
	# 004	001		# 004	000
	# 005	000		# 005	000
	# 006	000		# 006	000
	# 007	000		# 007	000
	# 008	000		# 008	000
	# 009	000		# 009	000
OEM C	# 010	000	# 010	000	
	# 000	000	OEM D	# 000	000
	# 001	002		# 001	003
	# 002	000		# 002	001
	# 003	000		# 003	000
	# 004	001		# 004	001
	# 005	000		# 005	000
	# 006	002		# 006	000
	# 007	000		# 007	000
	# 008	000		# 008	000
# 009	000	# 009		000	
OEM E	# 010	000	Portable Type	# 010	000
	# 000	000		# 000	000
	# 001	003		# 001	004
	# 002	001		# 002	001
	# 003	000		# 003	000
	# 004	001		# 004	000
	# 005	000		# 005	000
	# 006	000		# 006	000
	# 007	000		# 007	000
	# 008	000		# 008	000
# 009	000	# 009	000		
Debug Type	# 010	000	# 010	000	
	# 000	000	# 000	000	
	# 001	000	# 001	000	
	# 002	000	# 002	000	
	# 003	000	# 003	000	
	# 004	000	# 004	000	
	# 005	000	# 005	000	
	# 006	000	# 006	000	
	# 007	000	# 007	000	
	# 008	000	# 008	000	
# 009	000	# 009	000		
# 010	000	# 010	000		

# 9. EXTERNAL DIMENSIONS in mm

(1) Internal type I CPU rack

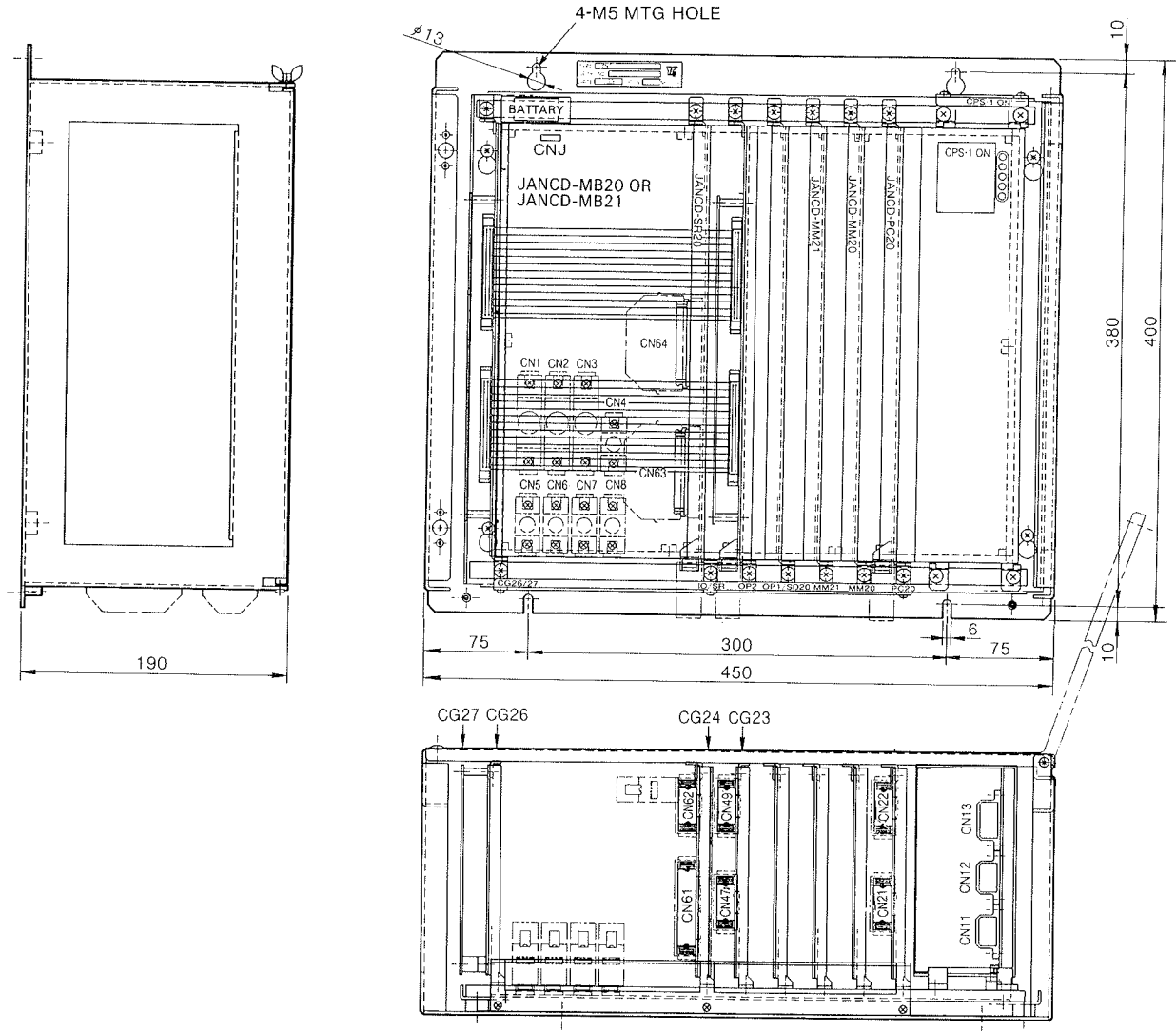

# 9. EXTERNAL DIMENSIONS in mm (Cont'd)

(2) Internal type II CPU rack

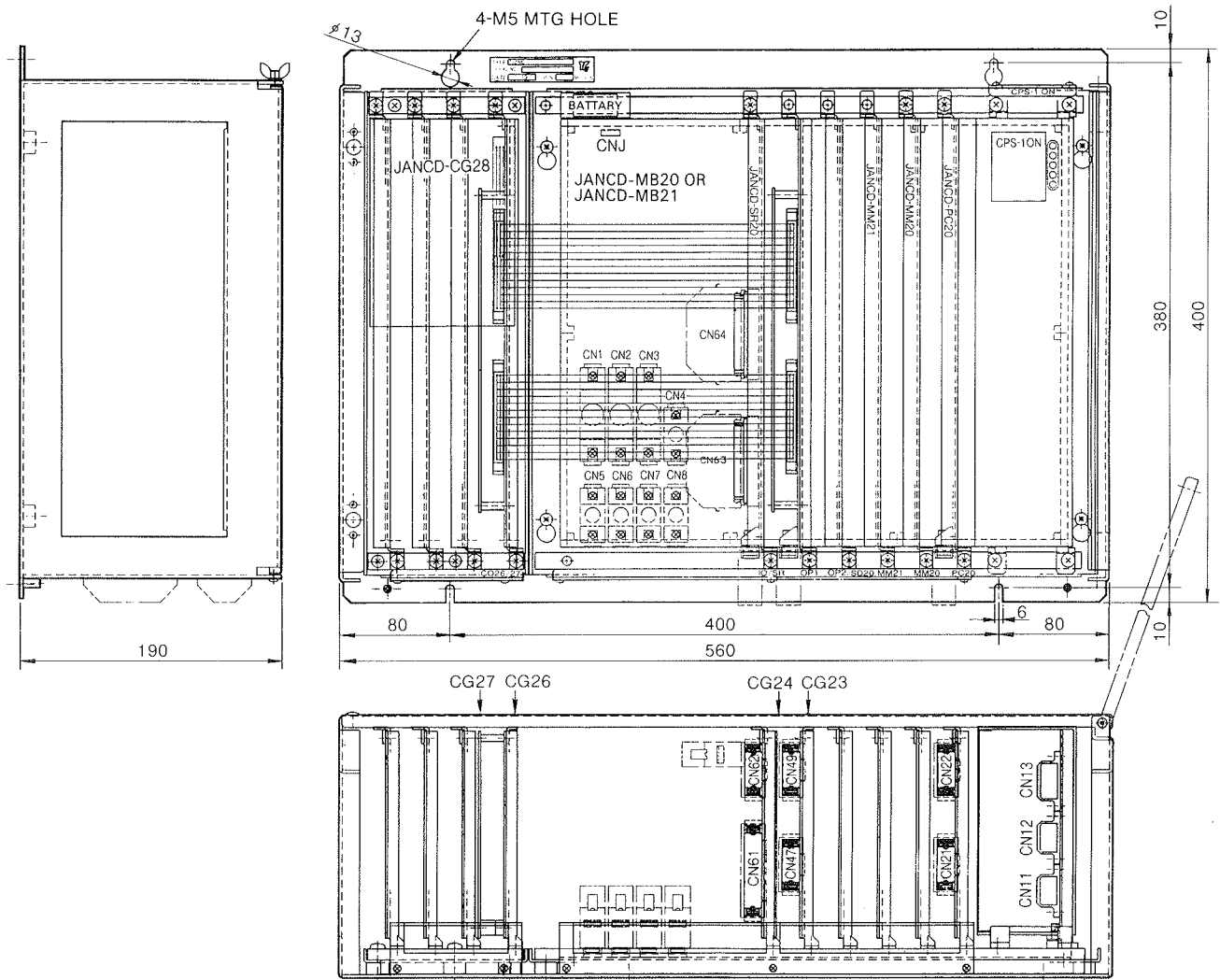

(3) Horizontal control panel

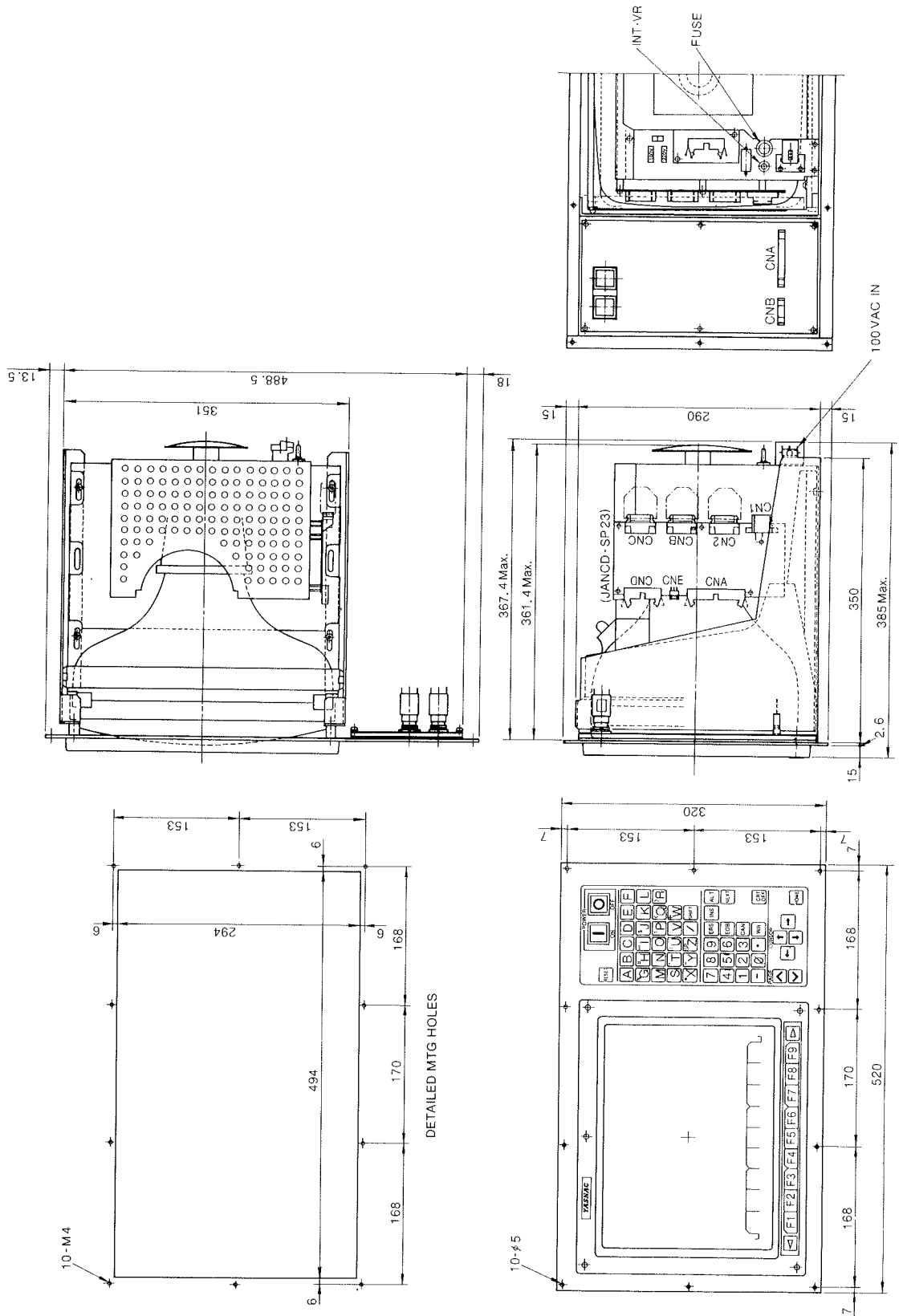

## 9. EXTERNAL DIMENSIONS in mm (Cont'd)

### (4) Vertical control panel

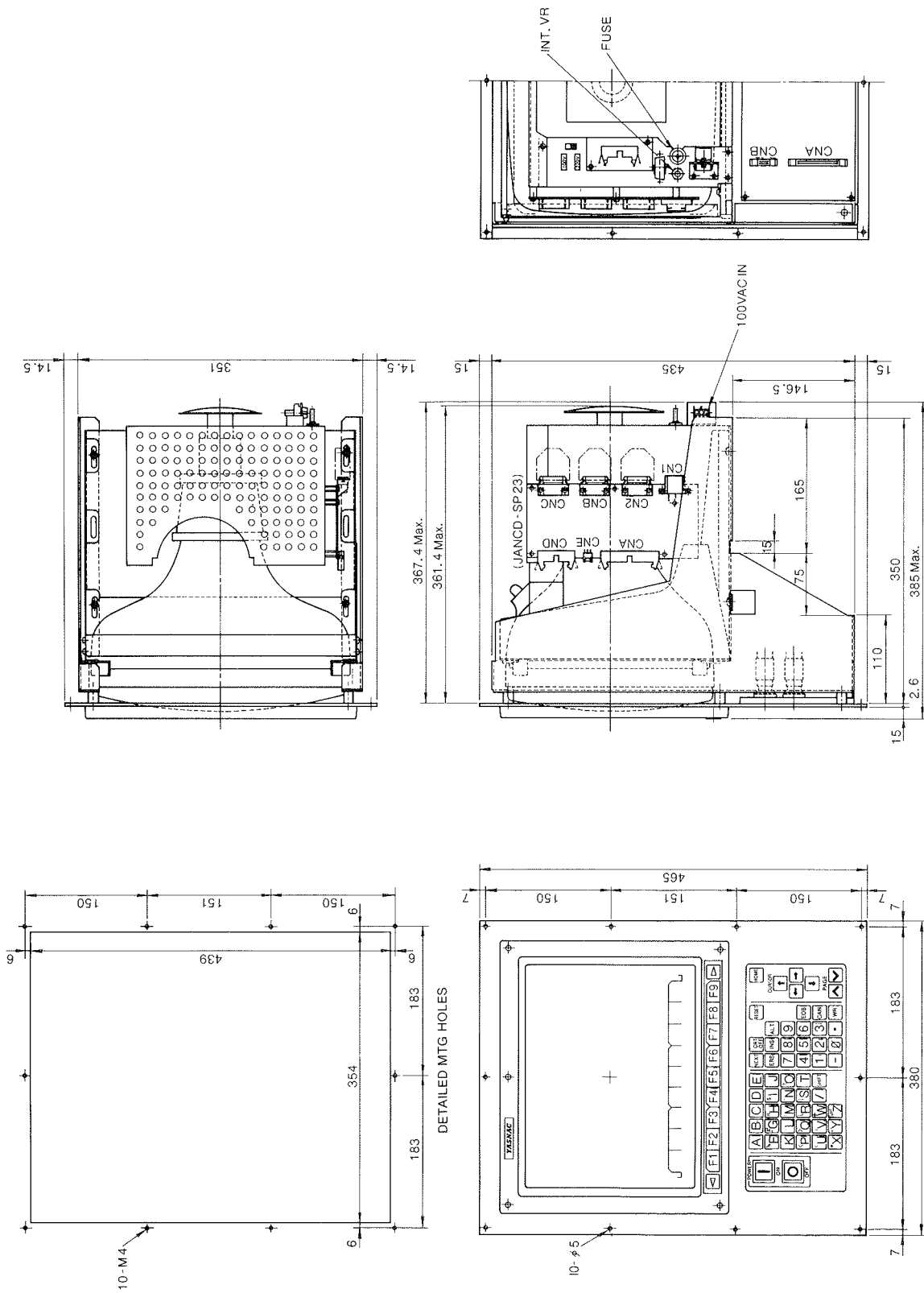

## 10. BATTERY MAINTENANCE

### 11.1 INDICATION OF BATTERY ALARM

A battery to backup the RAM and clock IC is mounted on the JANCD-CG26 module.

When this battery is not mounted, or if the battery has deteriorated, the battery alarm display will appear when the ACGC power is supplied, to indicate that the battery is failing. If this display appears, replace the battery within one month.

Commercially available batteries cannot be used here. Contact your Yaskawa representative.

# BATTERY ALARM

PLEASE EXCHANGE BATTERY (FOR ACGC DATA MEMORY)

Battery Alarm Display

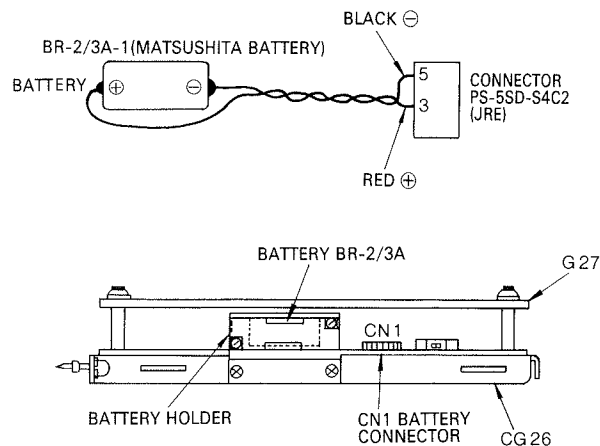

## 10.2 BATTERY REPLACEMENT PROCEDURE

- (1) Supply power. (Initial supply is sufficient)
- (2) Check that the LED1 (red) above the CNA connector (with flat cable on the upper part) of the JANCD-CG26 module is on. LED1 is on to indicate that the battery must be replaced.
- (3) Remove the old battery with power supplied. If the old battery is removed without supplying power, the stored data will be lost. Be very careful of electric shock, as this step is performed with power supplied.
- (4) Insert the new battery into the holder, and connect connector CN1. The direction of the connector is not important as long as the connection is firm. If not, there will be no conduction.

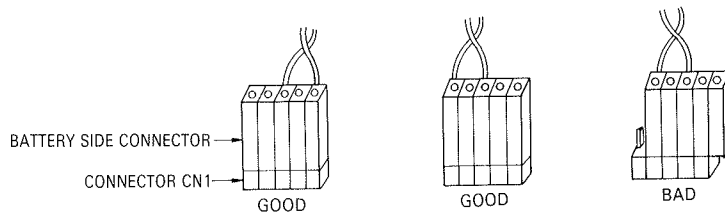

- (5) Turn the power off and then on again.

Check that the battery alarm on the CRT, as well as LED1 are off. If not, the connector is not correctly inserted (wrong position), or the battery is failing.





A Better Tomorrow for Industry through Automation

**YASKAWA Electric Mfg. Co., Ltd.**

**TOKYO OFFICE** Ohtemachi Bldg., 1-6-1 Ohtemachi, Chiyoda-ku, Tokyo, 100 Japan  
Phone (03) 284-9111, -9145 Telex YASKAWA J33530 Fax (03) 284-9034

**SEOUL OFFICE** Seoul Center Bldg., 91-1, So Kong-Dong, Chung-Ku, Seoul, Korea  
Phone (02) 776-7844 Fax (02) 753-2639

**SINGAPORE OFFICE** CPF Bldg., 79 Robinson Road No. 24-03, Singapore 0106  
Phone 2217530 Telex (87) 24890 YASKAWA RS Fax (65) 224-5854

**TAIPEI OFFICE** Union Commercial Bldg., 137, Nanking East Road, Sec. 2, Taipei, Taiwan  
Phone (02) 507-7065, -7732 Fax (02) 506-3837

**YASKAWA ELECTRIC AMERICA, INC. : SUBSIDIARY**

**Chicago Office (Head Office)** 3160 MacArthur Blvd., Northbrook, Illinois 60062-1917, U.S.A.  
Phone (312) 291-2340 Telex (230) 270197 YSKW YSNC NBRK Fax (312) 498-2430

**Los Angeles Office** 7341 Lincoln Way, Garden Grove, California 92641, U.S.A.  
Phone (714) 894-5911 Telex (230) 678396 YASKAWAUS TSTN Fax (714) 894-3258

**New Jersey Office** 30 Two Bridges Road, Fairfield, New Jersey 07006, U.S.A.  
Phone (201) 575-5940 Fax (201) 575-5947

**YASKAWA ELECTRIC EUROPE GmbH : SUBSIDIARY**

Monschauerstrasse 1, 4000 Düsseldorf 11, West Germany  
Phone (0211) 501127 Telex (41) 8588673 YASD D Fax (0211) 507737

**YASKAWA ELÉTRICO DO BRASIL COMÉRCIO LTDA. : SUBSIDIARY**  
Av. Brig. Faria Lima, 1664-cj, 721/724, Pinheiros, São Paulo-SP, Brasil CEP-01452  
Phone (011) 813-3933, 813-3694 Telex (011) 39881 TAFE-BR

*Due to ongoing product modification/improvement, data subject to change without notice.*